



650V / 10A

AAC010H06DC

SiC Schottky Barrier Diode

ACTRON TECHNOLOGY CORP.

Features

- Shorter recovery time
- High speed switching
- High surge current capability
- Enabling higher frequency and increased power density
- System efficiency improvement
- System cost and size savings due to the reduced cooling requirements

Outline (TO220-2L)

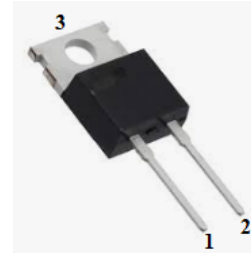

Applications

- Power Factor Correction in SMPS
- Solar inverter
- Uninterruptible Power Supply
- Motor Drives
- Data Center

Circuit Diagram

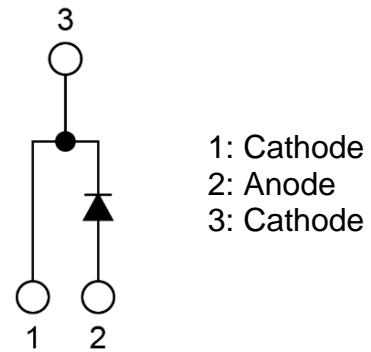

Mechanical Characteristics

- TO220-2L package
- Halogen Free
- Pb free lead plating ; RoHS compliant
- Packaging: Tube

Marking Diagram

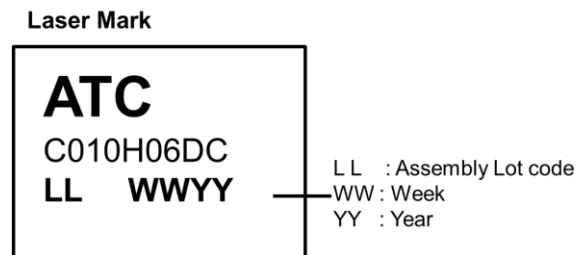



650V / 10A

AAC010H06DC

SiC Schottky Barrier Diode

ACTRON TECHNOLOGY CORP.

Parameter and Specification

Absolute Maximum Rating⁽¹⁾

Parameter	Symbol	Condition	Value	Unit
Repetitive peak reverse voltage	V_{RM}	$T_c=25^{\circ}C$	650	V
Continue forward current	I_F	$T_c=135^{\circ}C$	10	A
Surge non-repetitive forward current , sine half-wave	I_{FSM}	$T_c=25^{\circ}C, t_p=10ms, \text{Sine half wave}$	90	A
		$T_c=110^{\circ}C, t_p=10ms, \text{Sine half wave}$	72	
Surge repetitive forward current	I_{FRM}	$T_c=25^{\circ}C, t_p=10ms, \text{Sine half wave}$	40	A
I^2t value	$\int I^2t$	$T_c=25^{\circ}C, t_p=10ms, \text{Sine half wave}$	40	A^2s
Total power dissipation	P_D	$T_c=25^{\circ}C$	96	W
		$T_c=110^{\circ}C$	42	
Junction temperature	T_j		175	$^{\circ}C$
Storage temperature	T_{STG}		-55 ~ 175	$^{\circ}C$

Note :

(1) Exceeding these ratings may damage the device.

Thermal Characteristics

Parameter	Symbol	Condition	Typ.	Unit
Thermal resistance	θ_{jc}	Junction - Case	1.3	$^{\circ}C / W$



650V / 10A

AAC010H06DC

SiC Schottky Barrier Diode

ACTRON TECHNOLOGY CORP.

Electrical Characteristics

Characteristic	Symbol	Condition	MIN	TYP	MAX	Unit
DC reverse voltage	V_{DC}	$T_j = 25^{\circ}C, I_R = 50\mu A$	650	-	-	V
Forward voltage	V_F	$T_j = 25^{\circ}C, I_F = 10A$	-	1.35	1.5	V
		$T_j = 150^{\circ}C, I_F = 10A$	-	1.6	-	
		$T_j = 175^{\circ}C, I_F = 10A$	-	1.7	-	
Reverse current	I_R	$T_j = 25^{\circ}C, V_R = 650V$	-	2	50	uA
		$T_j = 150^{\circ}C, V_R = 650V$	-	8	-	
		$T_j = 175^{\circ}C, V_R = 650V$	-	15	-	
Total capacity charge	Q_C	$T_j = 25^{\circ}C, V_R = 400V,$ $di/dt = 350A/us$	-	24	-	nC
Total capacitance	C_{TOT}	$T_j = 25^{\circ}C, V_R = 1V,$ $F = 1MHz$	-	410	-	pF
		$T_j = 25^{\circ}C, V_R = 400V,$ $F = 1MHz$	-	40	-	
		$T_j = 25^{\circ}C, V_R = 650V,$ $F = 1MHz$	-	39	-	
Capacitance Stored Energy	E_C	$V_R = 400V$	-	4	-	μJ



650V / 10A

AAC010H06DC

SiC Schottky Barrier Diode

ACTRON TECHNOLOGY CORP.

Electrical Characteristic Curves

V_F – I_F Characteristics

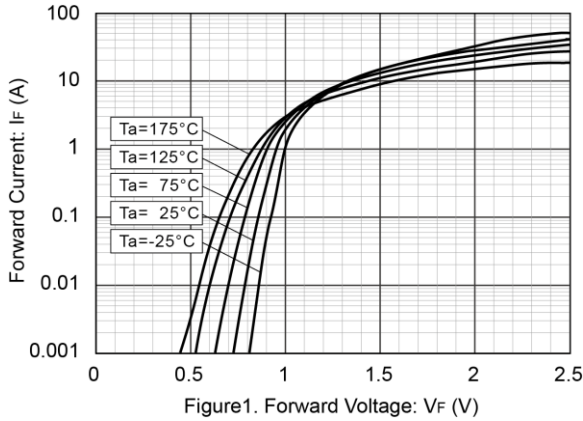

V_F – I_F Characteristics

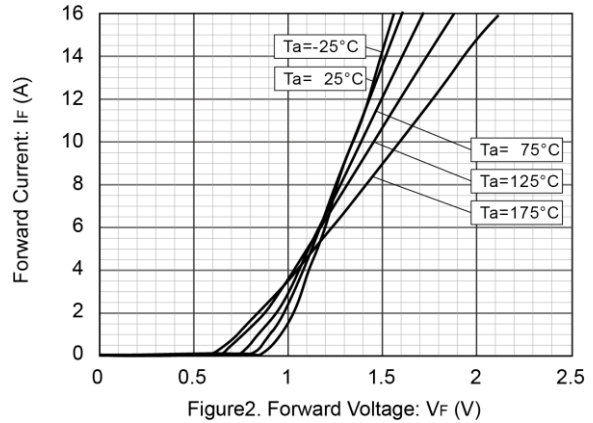

V_R – I_R Characteristics

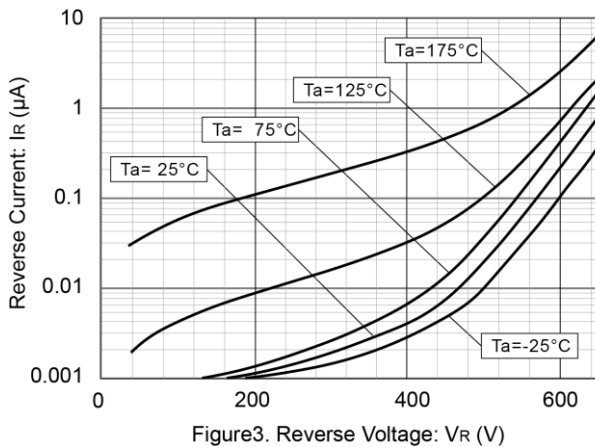

V_R – C_t Characteristics

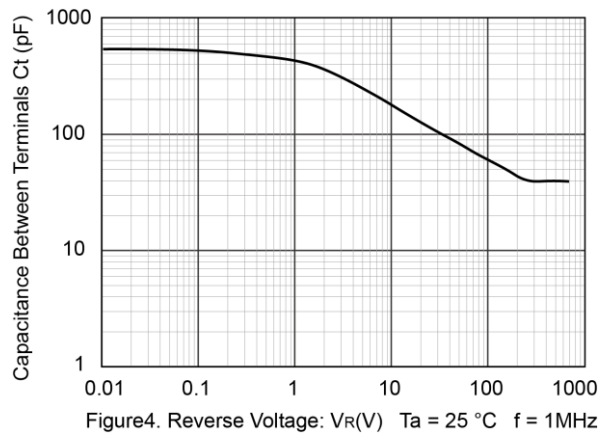

Maximum I_P – T_C Characteristics

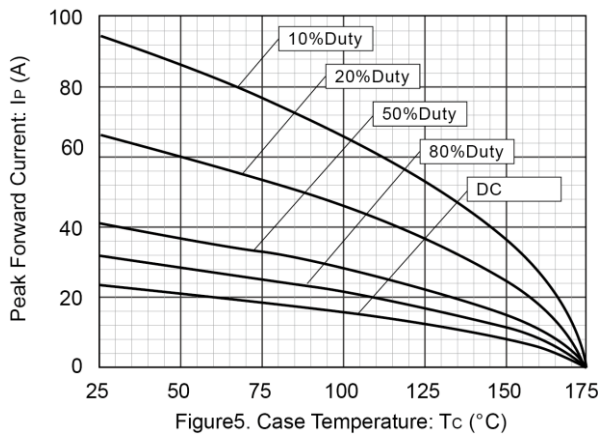

Power Dissipation

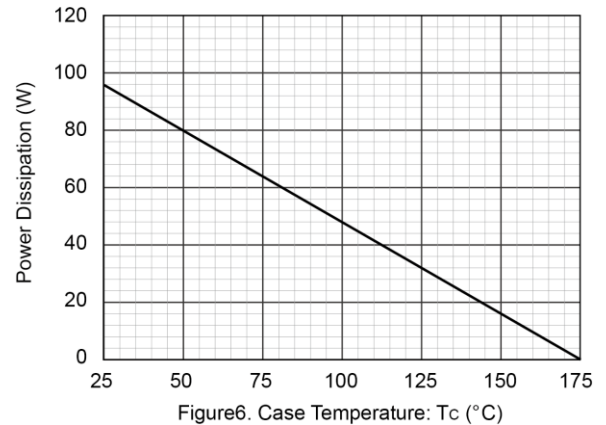



650V / 10A

AAC010H06DC

SiC Schottky Barrier Diode

ACTRON TECHNOLOGY CORP.

I_{FSM} – PW Characteristics

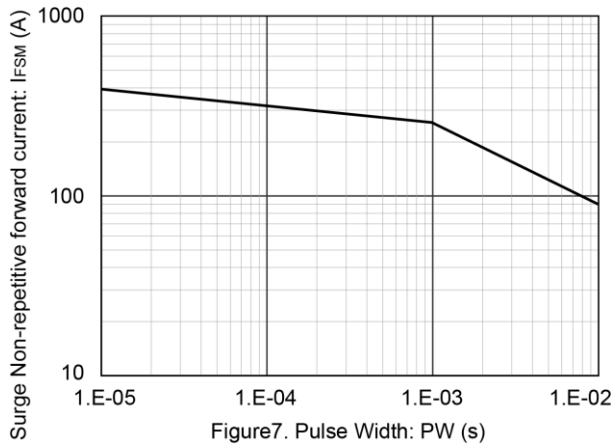

E_C – V_R Characteristics

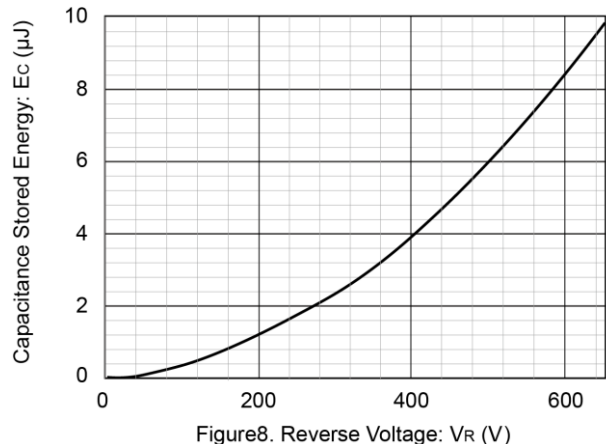

Typical Transient Thermal Resistance vs. Pulse Width

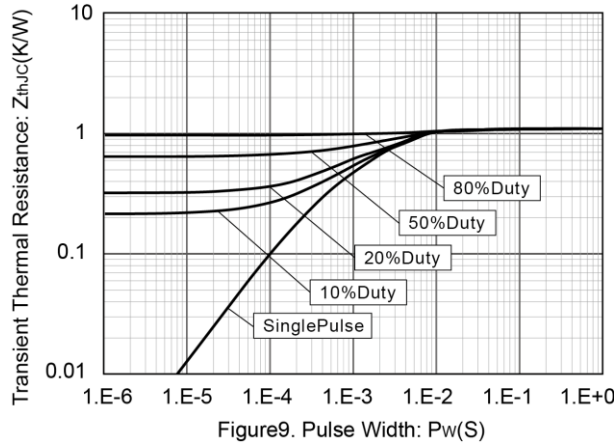

Simplified Forward Characteristic

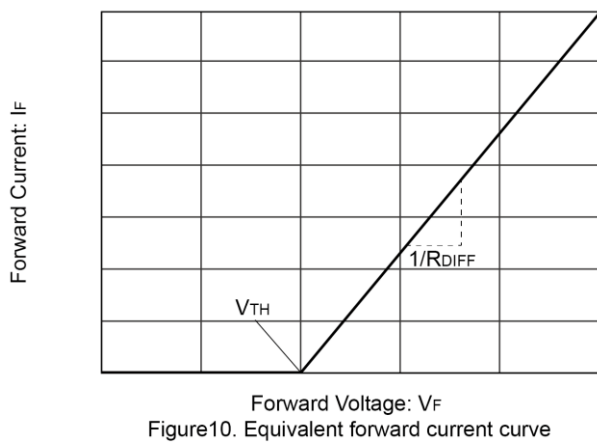

$$V_F = V_{TH} + R_{DIFF} \times I_F$$

Threshold Voltage (V_{TH}):

$$V_{TH}(T_j) = -0.0019 \times T_j + 0.78 [V]$$

Differential Resistance (R_{DIFF}):

$$R_{DIFF}(T_j) = A \times T_j^2 + B \times T_j + C [\Omega]$$

$$A = 2.0 \times 10^{-6}$$

$$B = 1.0 \times 10^{-4}$$

$$C = 4.21 \times 10^{-2}$$



Package Outline

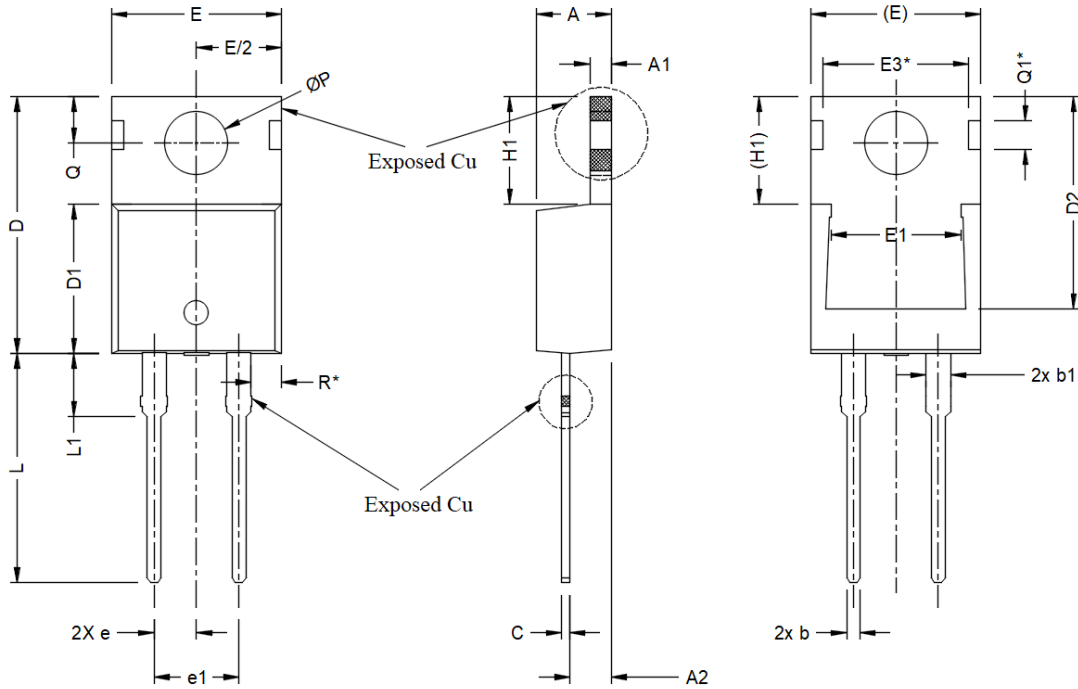

Unit : mm

SYMBOL	DIMENSIONS		
	MIN.	NOM.	MAX.
A	4.24	4.44	4.64
A1	1.15	1.27	1.40
A2	2.30	2.48	2.70
b	0.70	0.80	0.90
b1	1.20	1.45	1.70
c	0.40	0.50	0.60
D	14.70	15.37	16.00
D1	8.82	8.92	9.02
D2	12.43	12.73	12.83
E	9.96	10.16	10.36
E1	6.86	7.77	8.89
E3*	8.70 REF.		
e	2.54 BSC		
e1	5.08 BSC		
H1	6.30	6.45	6.60
L	13.47	13.72	13.97
L1	3.60	3.80	4.00
$\varnothing P$	3.75	3.84	3.93
Q	2.60	2.80	3.00
Q1*	1.73 REF.		
R*	1.82 REF.		